

# Data Storage by the Hard Disk Drive

**Mitsumasa Oshiki**

**Storage Research Consortium (*SRC*)**

**2008.10.24**

# Storage Research Consortium (SRC)

情報ストレージ研究推進機構

★ SRC: Established in 1995

## Purpose of establishment

To enhance HDD related technology research vitality and competitiveness,

- Foster healthy pre-competitive collaboration among companies to develop HDD roadmap, which mitigates R&D/tooling investment risks
- Share competitive research targets with leading university on advanced HDD tech
- Offer scholarship to talented doctoral students to be future HDD-related core researchers
- Establish COE for storage technology research

1<sup>st</sup> period: R&D Goal (~ 2000)

20 Gb/in<sup>2</sup> HDD technology

2<sup>nd</sup> period: R&D Goal (~ 2003)

200 Gb/in<sup>2</sup> HDD technology

3<sup>rd</sup> period: R&D Goal (~ 2005)

600 Gb/in<sup>2</sup> HDD technology

4<sup>th</sup> period: R&D Goal (~ 2010)

(Ph1 ~'08.9) 1 Tb/in<sup>2</sup> HDD Technology

(Ph2 ~'10.6) 2 Tb/in<sup>2</sup> HDD Technology

1995-2006 (Cumulative total: \1.68B)

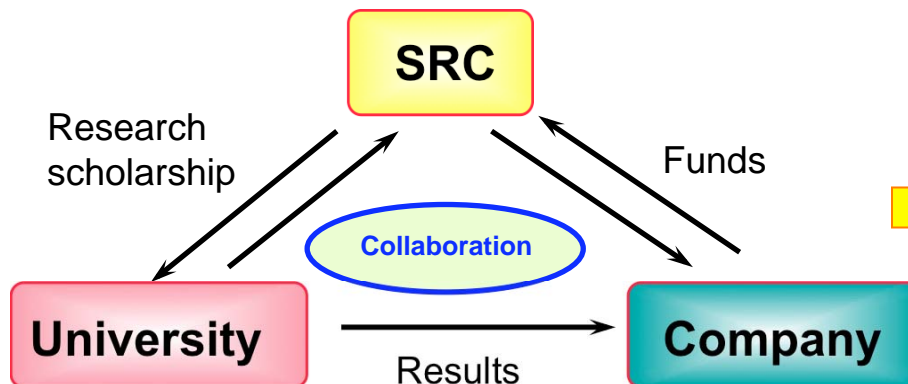

**Strengthen competitiveness of storage industry**

Mid-term - Long term  
In-depth/frontier research<sub>2</sub>  
Intellectual properties

# Hard Disk Drive (HDD)

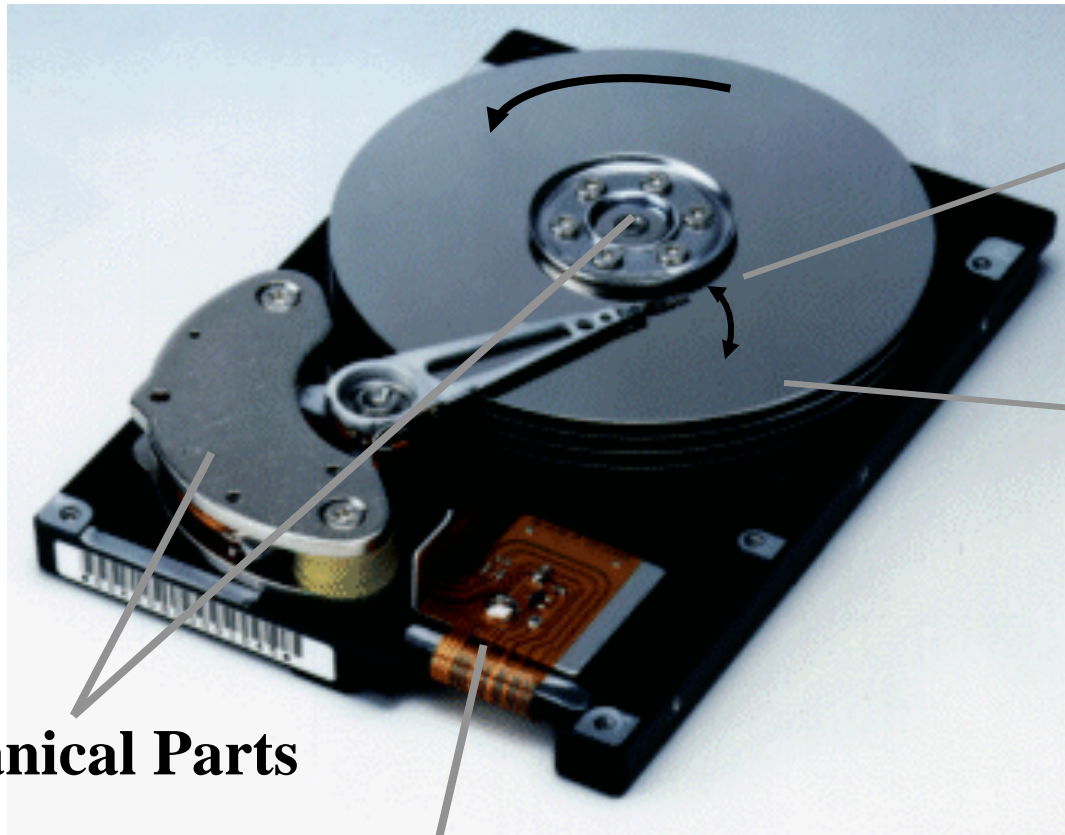

**Magnetic  
Read write Head**

**Magnetic  
Recording Medium**

**Mechanical Parts**

**Electric Circuits**

# Magnetic Recording

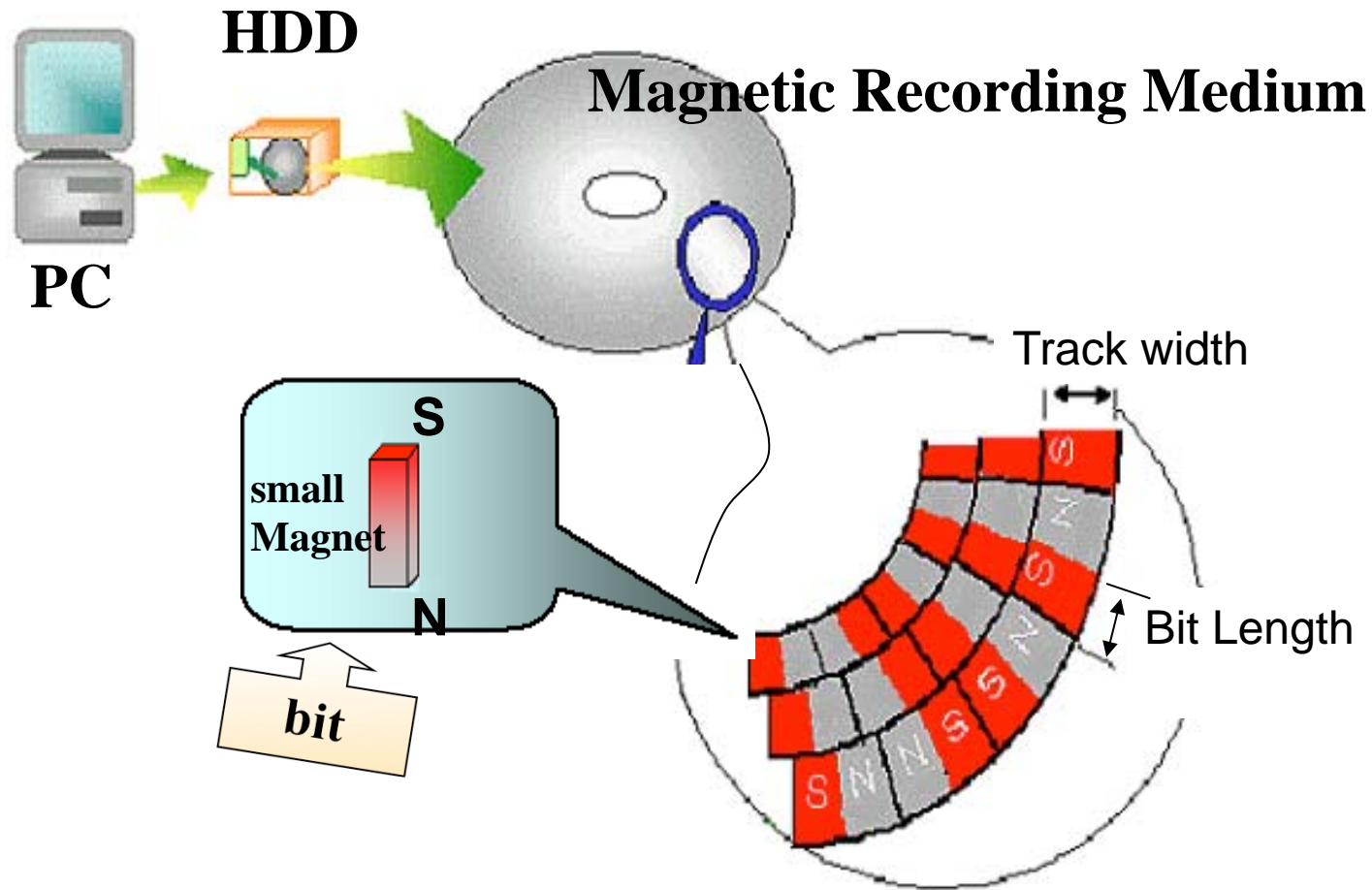

# Perpendicular Recording Medium

CoPtCr-SiO<sub>2</sub> media

粒径 ( $D_{\text{grain}}$ ) : 6.2 nm  
 $\sigma / D_{\text{grain}}$  : 0.21

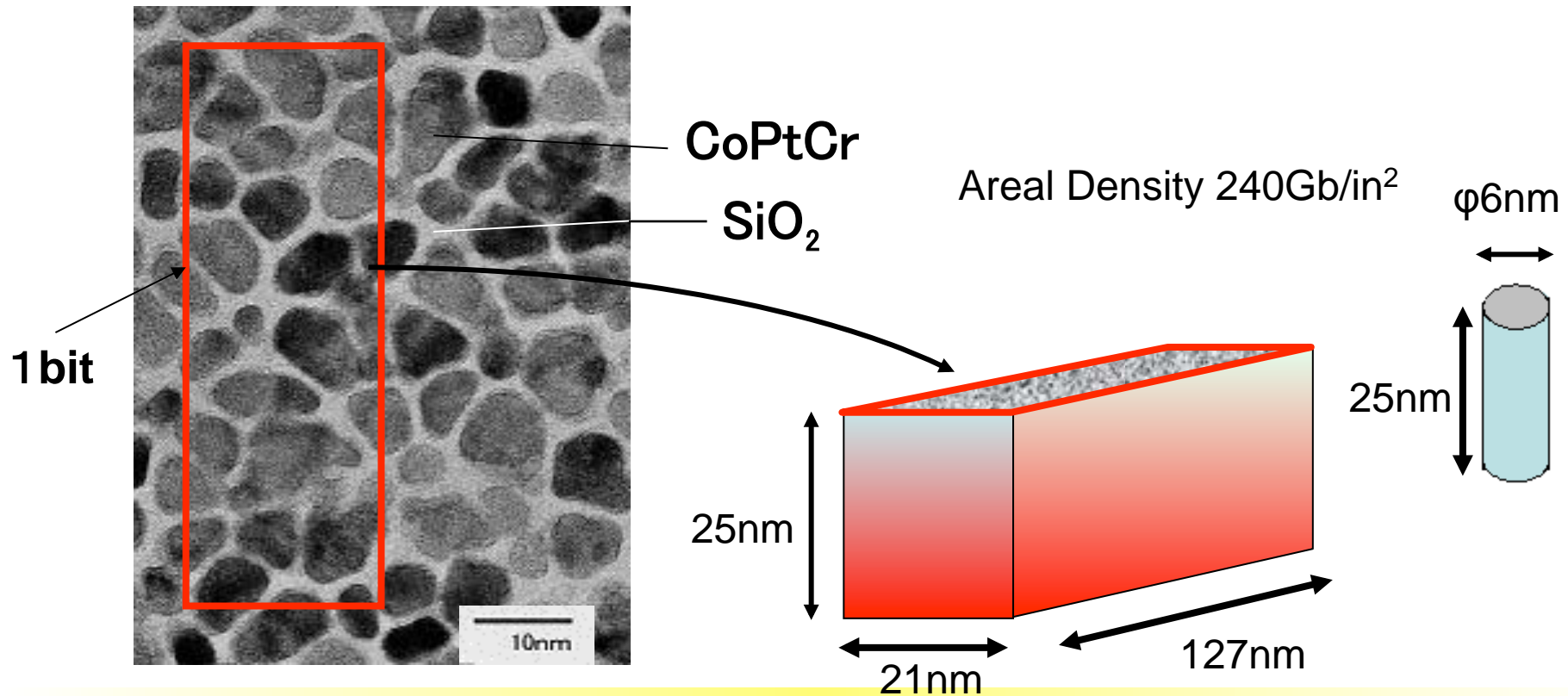

# Magnetic Head

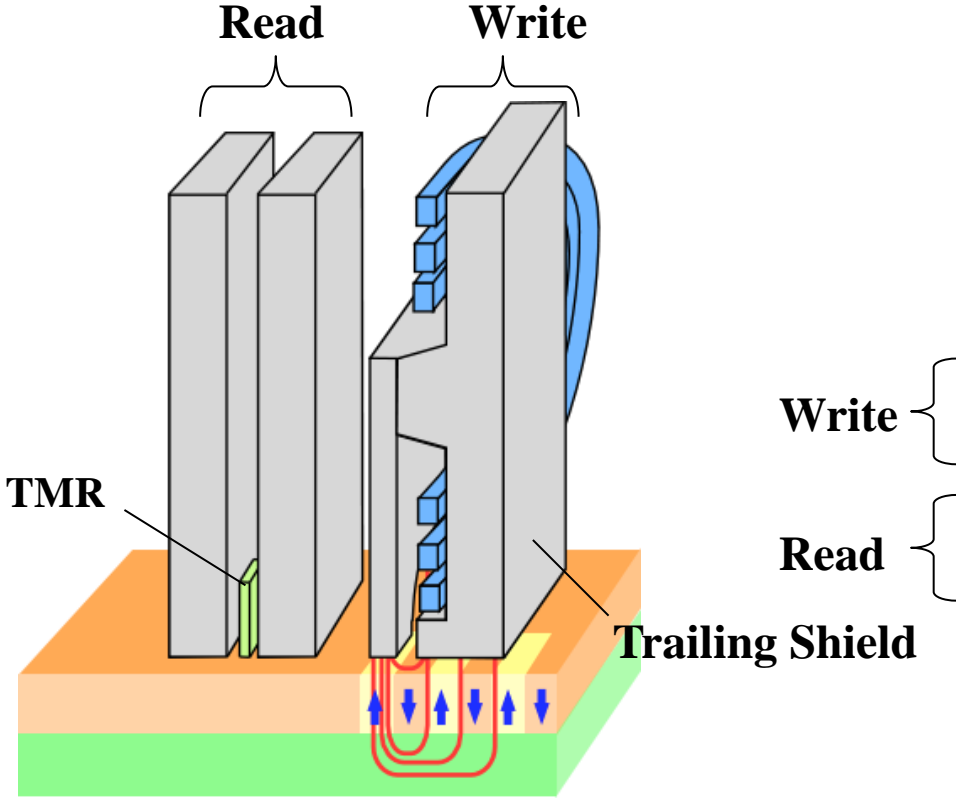

Thin Film Head

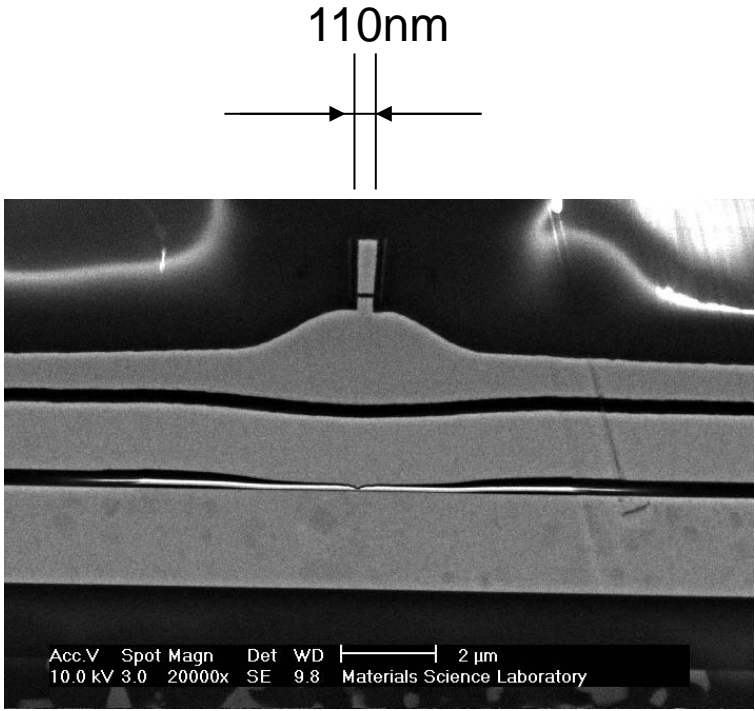

SEM Image

# Head - Medium Interface

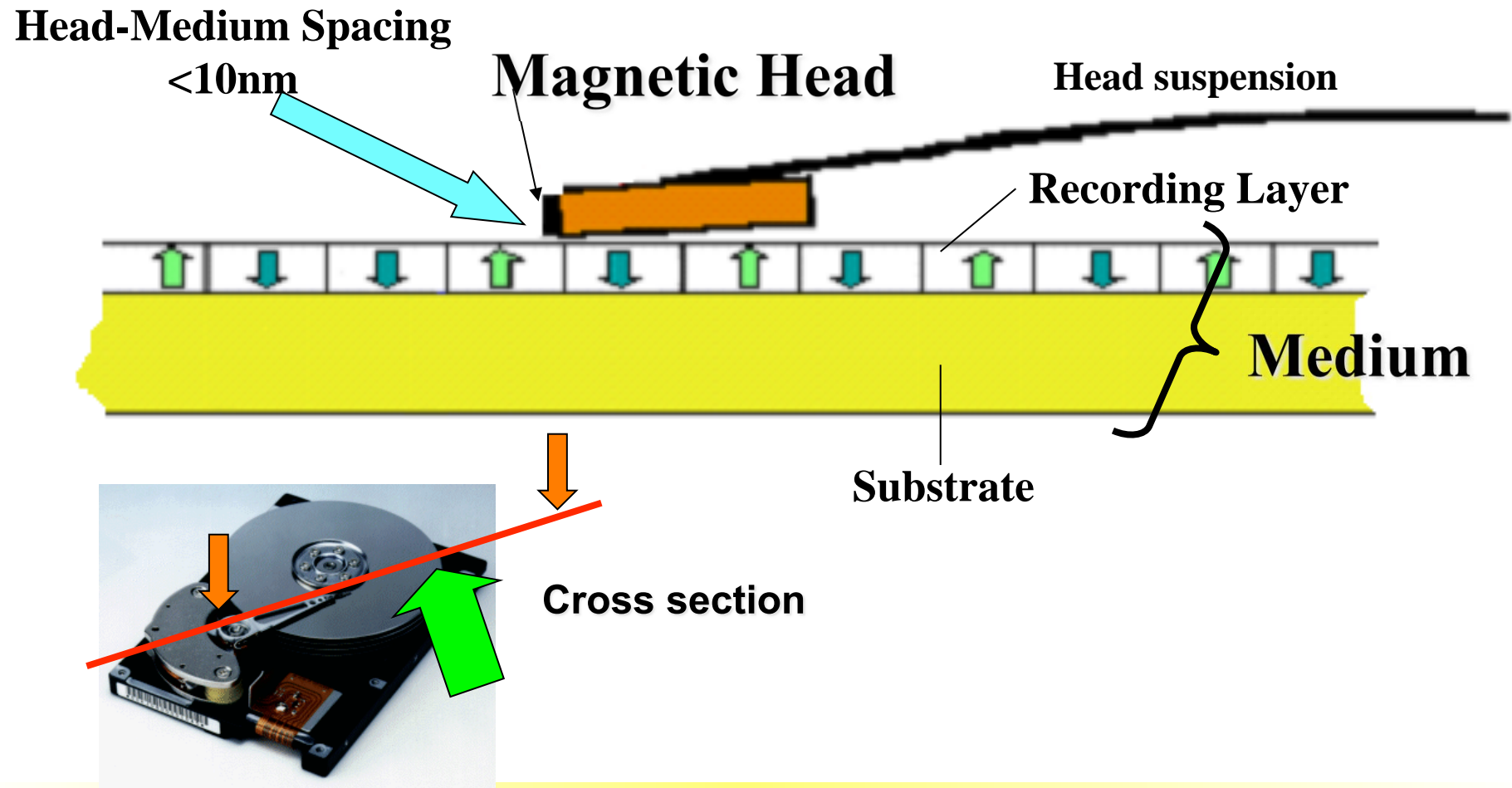

# Mechanical Parts

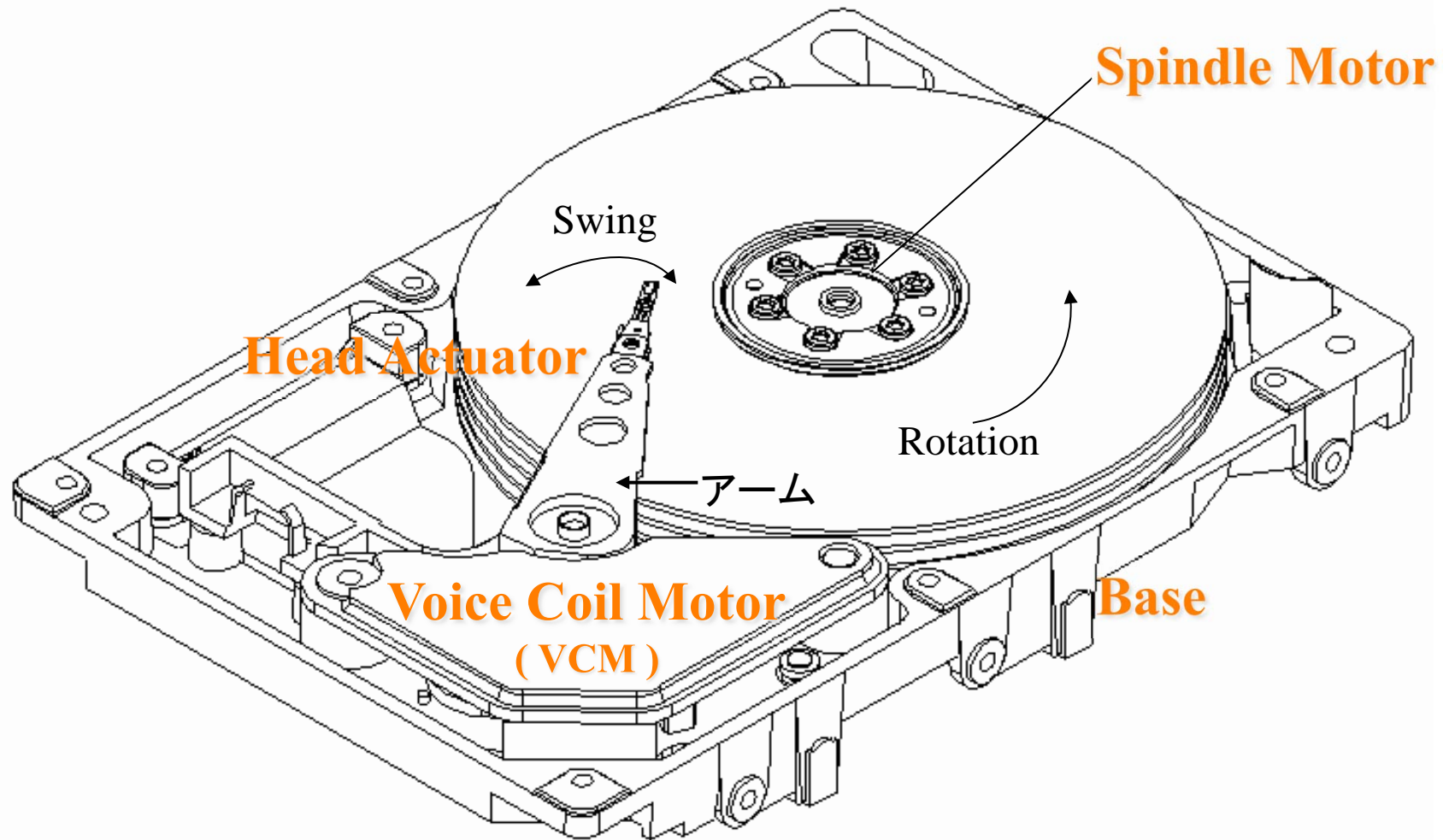

# Spindle Motor & Fluid Dynamic Bearing

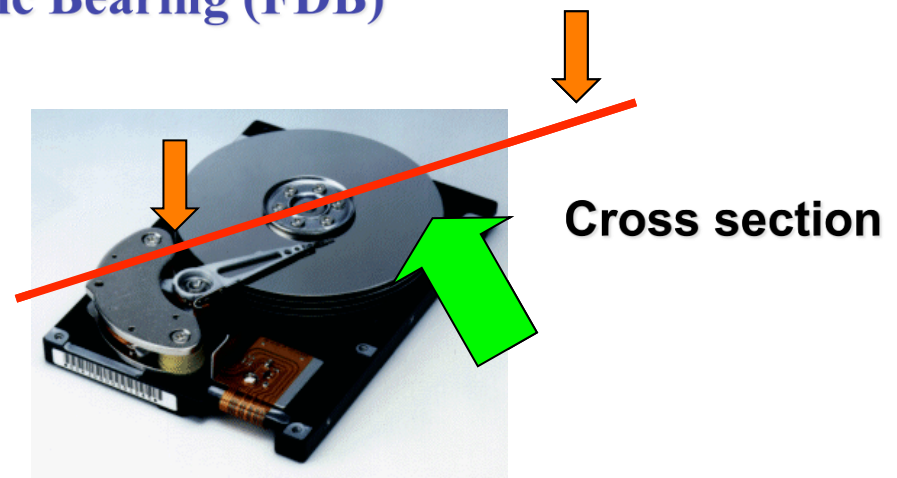
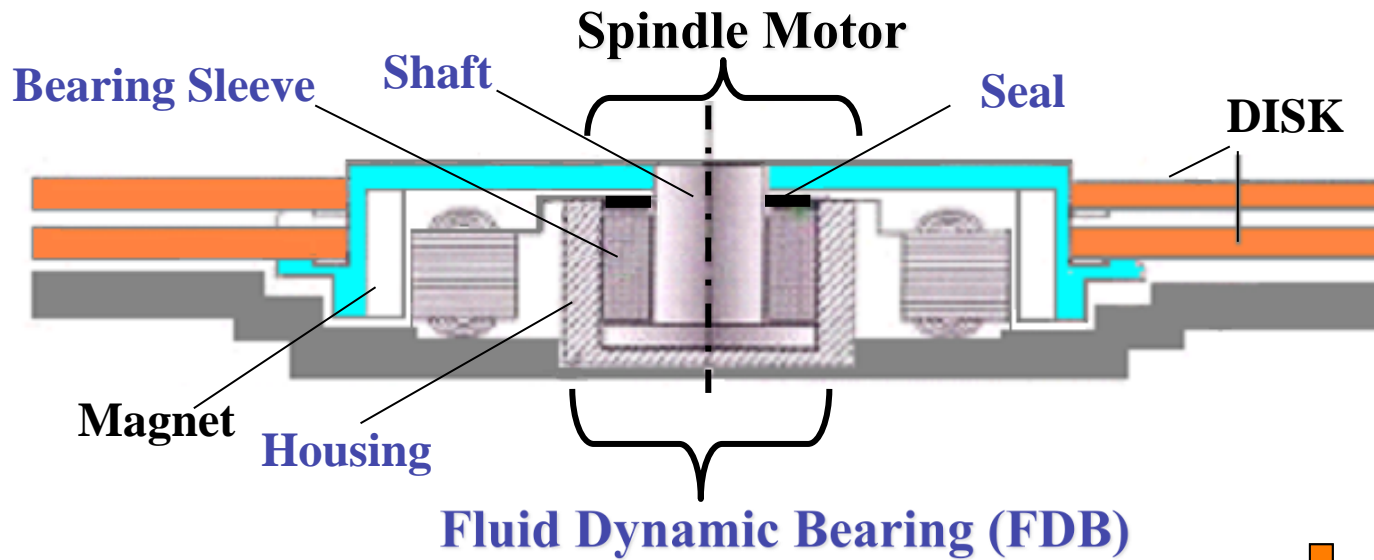

# Head Actuator

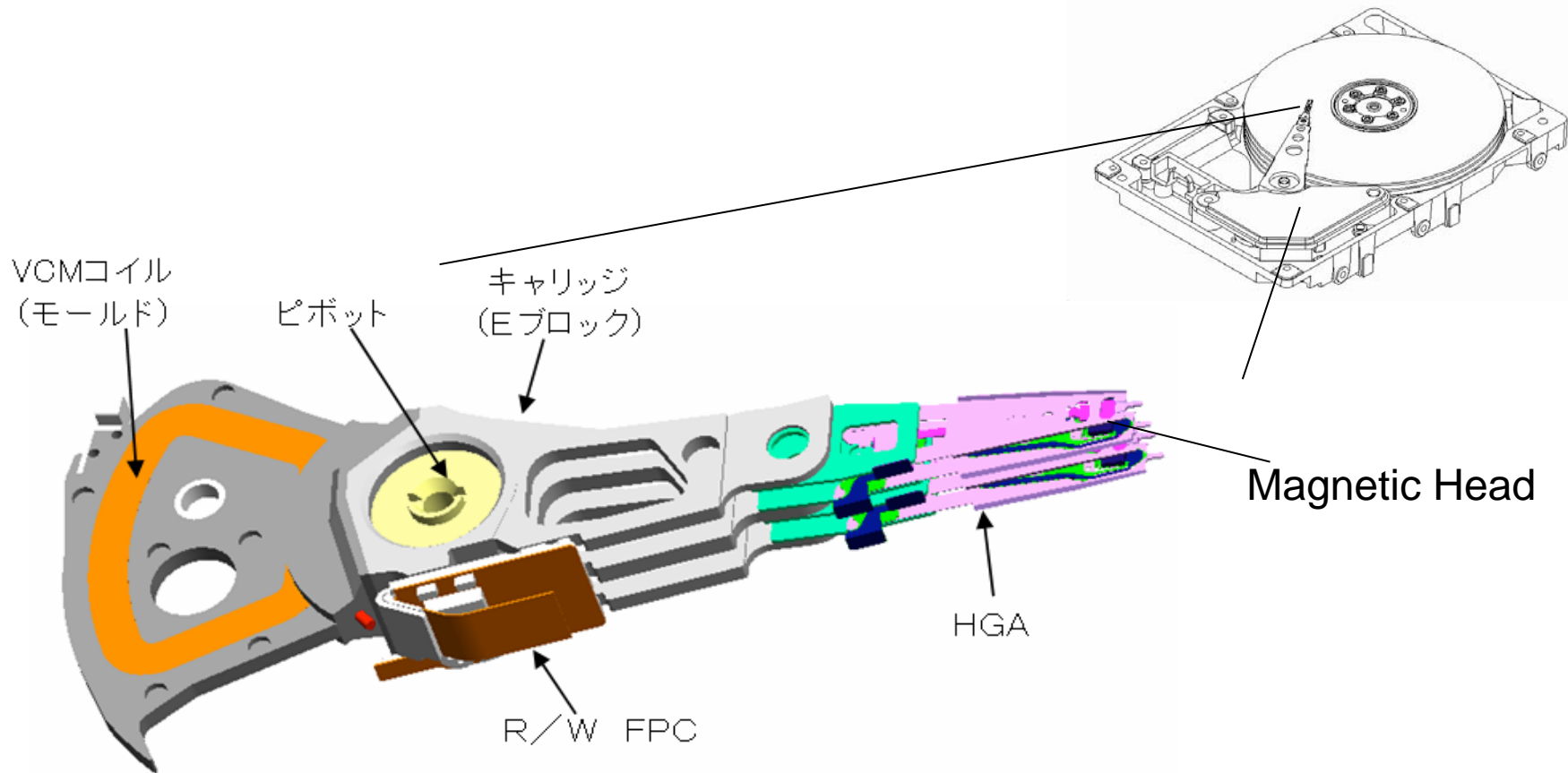

**VCM: Voice Coil Motor**

# Thermal Agitation

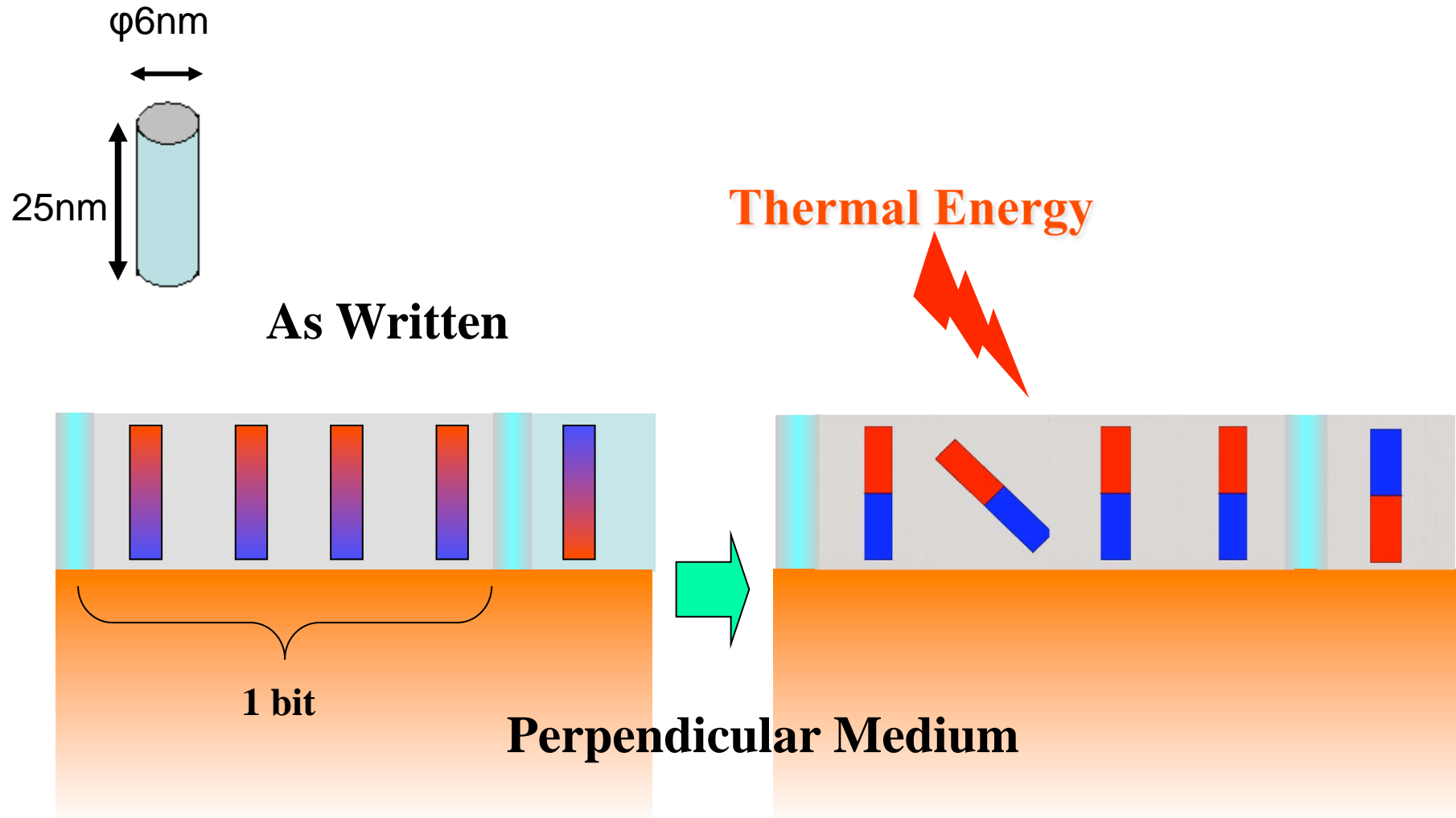

# Guarantee

**Guarantee : 5 years (Read / Write operation)**

**HDD is the super precision instrument**

- **Very narrow Head-Medium spacing (<10nm)**
- **Tiny recording bit (120nm×21nm×25nm)**
- **Very precise servo control (~10nm)**
- **Thin film recording layer**
- **Thin film laminated head**

**User needs**

- **Large recording capacity**
- **High performance**
- **Small footprint**
- **Low power consumption**
- **Low price**

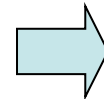

**Decrease Reliability**

# RAID (redundant array of independent disks)

Even if each HDD is broken, the data are saved.

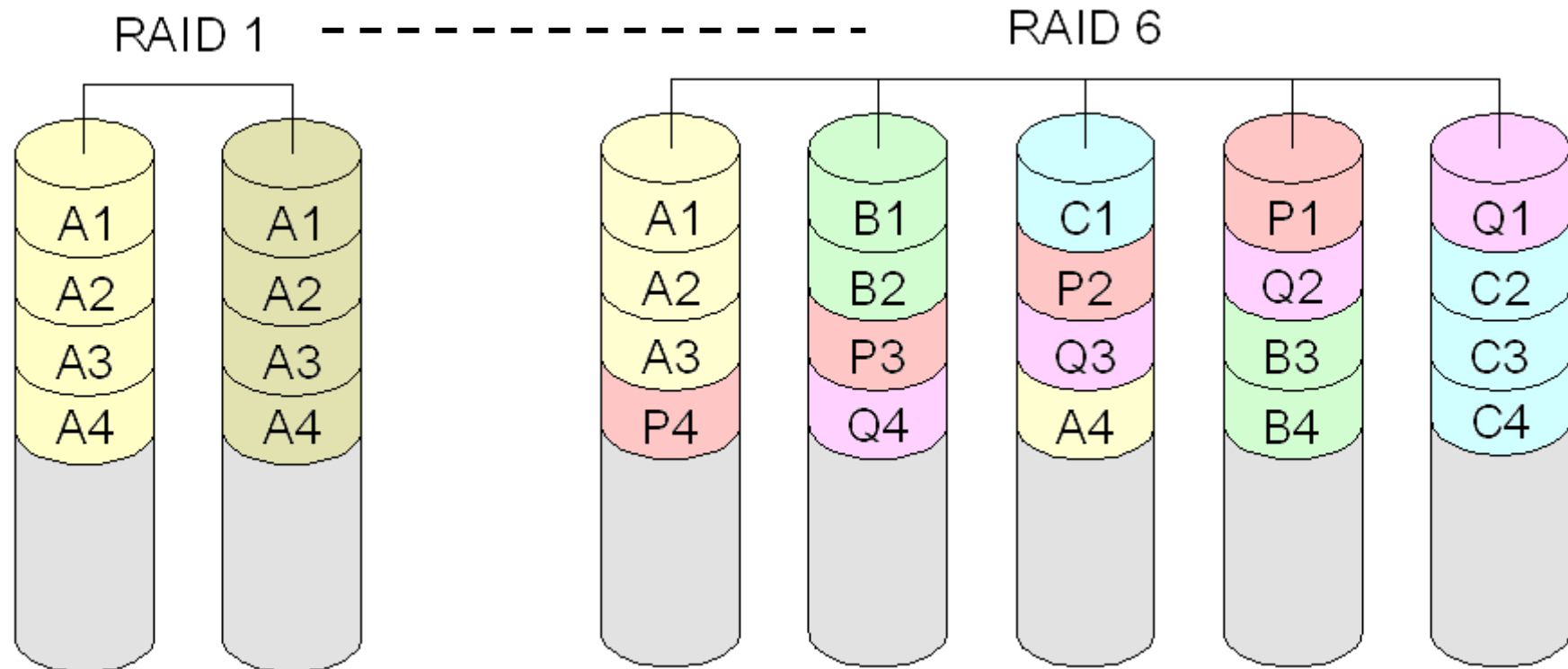

# Data Continuity



**HDD**

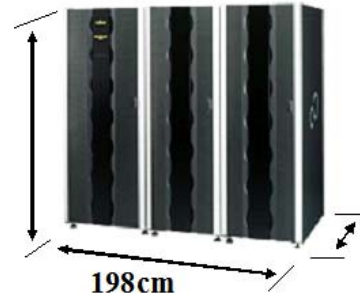

(HDD 480DE:354.2TB)

HDD 160DE mounted to a locker



(HDD 2,760DE:2,047.1TB)

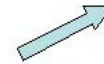

**Expand**

**Disk Array System**

## More Secure Storage : RAID

If each HDD is broken, new HDD replace.

**Most probable way**

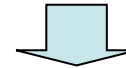

The data will be saved.

**Who ? When ? What ?**